



Komplete
MODULAR SOLUTIONS

FieldREADY™

Sewage Holding
// SUPPORT EQUIPMENT

164-1/2" (L) x 93-1/4" (W) x 28" (H)

1000 Gallon Low Profile Sewage Tank

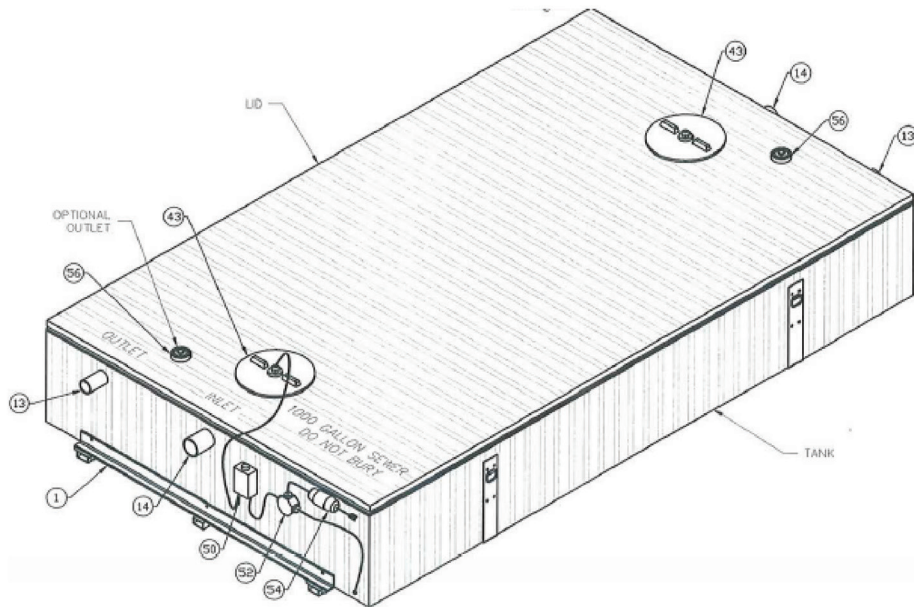

Highlights

This Structure Contains:

- 15 Amp, 120 Volts, Single Phase
- Stamped Engineered Drawings
- 1000 US Gallons / 832 Imperial Gallons / 3,785 Litres / 3.78 Cubic Meters
- CSA Variance (Plumbing) & Local AHJ Electrical Inspection
- Inlet Connection: 4" / 100mm DR11 (at each end) welded to HDPE liner
- Suck Out Connection: 3" / 75mm DR11 (at each end) welded to HDPE liner equipped with a gate valve
- Alarm Type: Float controlled alarm (field adjustable) visual & audible alarm
- Snow Load: Rated at 15lbs. per square foot
- Lifting Method: Skid mounted w/two hooks & equipped with (4) 1,000lb. welded D-Rings (empty only)
- R-Value: Approx. R-14
- Liner Type: Rotational molded HDPE (min. 3/16" thickness)
- Heat Trace: Raychem Wintergard Wet – 120V 6W/FT Self Regulating w/GFI Cord End
- Installation Restrictions: Must be level & properly supported (do not bury)
- Inspection Access: 16" Removable access lid at each end
- 1,200lbs. each



Komplete
MODULAR SOLUTIONS

FieldREADY™

Sewage Holding
// SUPPORT EQUIPMENT

164-1/2" (L) x 93-1/4" (W) x 28" (H)

1000 Gallon Low Profile Sewage Tank

